



*An Online PDH Course  
brought to you by  
CEDengineering.com*

## **Voltage Transformers**

Course No: E03-042  
Credit: 3 PDH

---

Velimir Lackovic, Char. Eng.

---



Continuing Education and Development, Inc.

P: (877) 322-5800  
[info@cedengineering.com](mailto:info@cedengineering.com)

## Introduction

There are two types of voltage transformers, magnetic voltage transformers (VT) and capacitive voltage transformers (CVT). The magnetic voltage transformers are most economical for voltages up to about 145 kV and the capacitive voltage transformers for voltages higher than 145 kV. A CVT can also be used together with the Power Line Carrier (PLC) devices that are used for communication over the high voltage transmission circuits.

Voltage transformers are together with current transformers known as instrument transformers. Voltage transformers are in most situations connected between phase and ground. The standard that describes voltage transformers in details is IEC 186.

The main functions of instrument transformers are:

- To transform currents or voltages from high value to a value that can be easily handled by protection relays and instruments.
- To insulate the metering circuit from the primary high voltage.
- To give standardization possibilities for instruments and protection relays to a few rated currents and voltages. Instrument transformers are specific types of transformers used for voltage and current measurements.

For the instrument transformers the typical engineering laws that are also used for power transformers can be applied.

For a short circuited transformer the Equation (1) can be used:

$$\frac{I_1}{I_2} = \frac{N_2}{N_1} \quad (1)$$

For a transformer in no load the Equation (2) can be used:

$$\frac{E_1}{E_2} = \frac{N_1}{N_2} \quad (2)$$

Equation (1) shows the current transformation in proportion to the primary and secondary turns. Equation (2) shows the voltage transformation in proportion to the primary and secondary turns. The working principle of the current transformer is based on Equation (1) and ideally a short-circuited transformer where the secondary terminal voltage is zero and the magnetizing current is negligible.

The working principle of the voltage transformer is based on Equation (2) and is ideally a transformer under no-load condition where the load current is zero and the voltage drop is created by the magnetizing current and is therefore negligible. In reality the ideal conditions are not met as the instrument transformers are loaded with burden in form of protection relays, instruments and cables. This creates a measuring error in the current transformer due to the magnetizing current and in the voltage transformer due to the load current voltage drop.

The vector diagram for a single phase instrument transformer is presented in Figure 1.

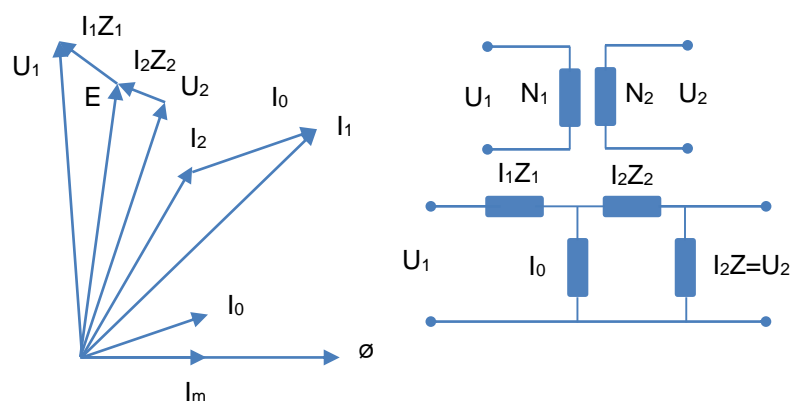

Figure 1. Instrument transformer operating principle

The turn ratio of the given instrument transformer is 1:1 to simplify the representation. The primary terminal voltage is  $U_1$ . The vectorial subtraction of the voltage drop  $I_1 Z_1$  from  $U_1$  gives the electromagnetic force  $E$ .  $E$  is also the vectorial sum of the secondary terminal voltage  $U_2$  and the secondary voltage drop  $I_2 Z_2$ . The secondary terminal voltage  $U_2$  can be written as  $I_2 Z$  where  $Z$  is the burden impedance.

The electromagnetic force  $E$  is created by the flux  $\emptyset$  that lags  $E$  by  $90^\circ$ . The flux is caused by the magnetizing current  $I_m$  which is in phase with  $\emptyset$ .  $I_m$  is the no-load current  $I_0$  reactive component and is in phase with  $E$ .

### Instrument Transformer Measuring Error

The voltage transformer is typically loaded by impedance consisting of protection relays, instruments and the cables. The induced electromagnetic force  $E$  needed to achieve the secondary current  $I_2$  through the complete burden  $Z_2+Z$ , needs a magnetizing current  $I_0$  which is taken from the primary side voltage. The  $I_0$  is not part of the voltage transformation and instead of the rated ratio  $K_n$ :

$$\frac{U_1}{U_2} = \text{Nominal ratio } K_n \quad (3)$$

The real voltage ratio  $K_d$  is expressed as:

$$\frac{U_1 - \Delta U}{U_2} = \text{Real ratio } K_d \quad (4)$$

where

$U_1$  is the rated voltage of the primary

$U_2$  is the rated voltage of the secondary

The measuring error  $\varepsilon$  is expressed using the Equation (5):

$$\frac{\frac{U_1}{U_2} - \frac{U_1 - \Delta U}{U_2}}{\frac{U_1}{U_2}} \times 100 = \frac{\Delta U}{U_1} \times 100 = \varepsilon(5)$$

where

$U_1$  is the voltage of the primary

$U_2$  is the voltage of the secondary

The reproduction error will appear both in magnitude and phase. The magnitude error is known as voltage or ratio error. According to the definition, the voltage error is positive if the secondary voltage is bigger than the rated voltage ratio would give.

The phase angle error is known as phase error or phase displacement. The phase error is positive if the voltage of the secondary is leading the primary.

According to the Figure (1) it can be written:

$$\Delta U = \Delta E_1 + \Delta E_2 \quad (6)$$

$$\Delta E_1 = I_1 Z_1 \quad (7)$$

$$\Delta E_2 = I_2 Z_2 \quad (8)$$

If  $Z_1 + Z_2 = Z_k$  and  $I_1 = I_0 + I_2$  it can be written

$$\Delta U = I_0 Z_1 + I_2 Z_k \quad (9)$$

Therefore, the voltage transformer is dependent of the voltage U and the flux density and magnetizing curve, and partly on the load current. The magnetizing current that creates the measuring error is dependent on several different factors as presented in Figure 2. The induced electromagnetic force also determines transformer capability to carry burden.

For the no load voltage drop  $I_0 Z_1$ , the following relations are valid:

$$I_0 = f(B) \quad (10)$$

$$I_0 Z_1 = f(B) * R_1 + j f(B) * X_1 \quad (11)$$

To achieve a low voltage drop following steps need to be taken:

- The primary winding is wound with a wire with big cross section
- A low induction is applied
- The reactance is kept low

This means that a big core cross section must be used so that high number of primary turns is avoided since the reactance has a square dependence on the number of turns. The load dependent voltage drop  $I_2 Z_k$  is expressed with Equation (12).

$$Z_k = R_1 + jX_1 + R_2 + jX_2 \quad (12)$$

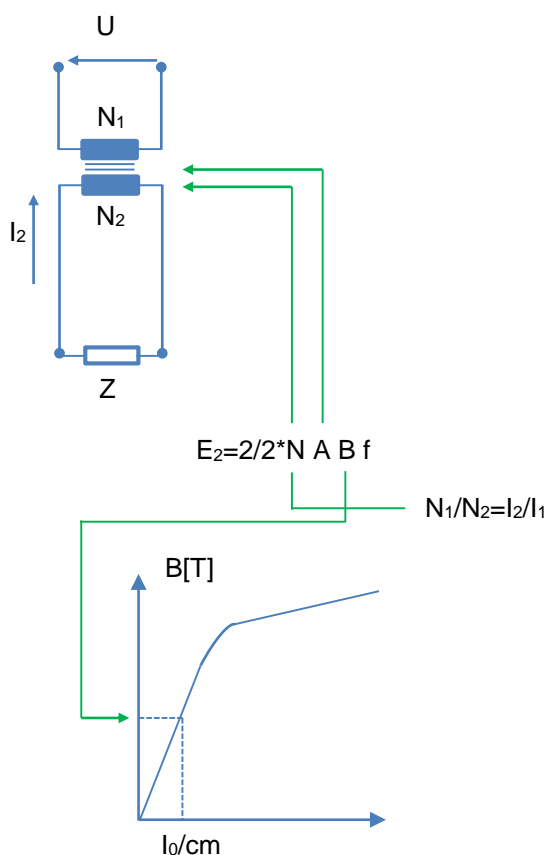

Figure 2. The factors affecting the voltage transformer output and magnetizing current

To maintain a low voltage drop due to the load current the impedances of the primary and secondary have to be kept as low as possible which in reality means that a winding with big cross section on the wires is used and the coils are made as compact as possible to decrease the leakage flux.

### The measuring error change with the voltage

The no load error  $I_0 Z_1$  changes with the voltage following the transformer magnetizing curve. The primary impedance  $Z_1$  can be considered as a constant. The voltage drop that depends on the load is proportional to  $U_2$  as  $I_2 = U_2/Z$  where  $Z$  is the connected burden and  $Z_1$  and  $Z_k$  are constants. Therefore, the relative voltage drop is constant. Turns correction is typically used on voltage transformers to reach high accuracy. The high number of turns provides a possibility to regulate in small

steps. According to IEC 186 a voltage transformer needs to fulfil its accuracy class for burdens between 25 and 100% of rated burden. Turns correction is usually chosen to give a positive error  $+\epsilon_{\max}$  at a burden of 25% of rated burden and  $-\epsilon_{\max}$  at a burden of 100% of rated burden. This is presented in Figure 3.

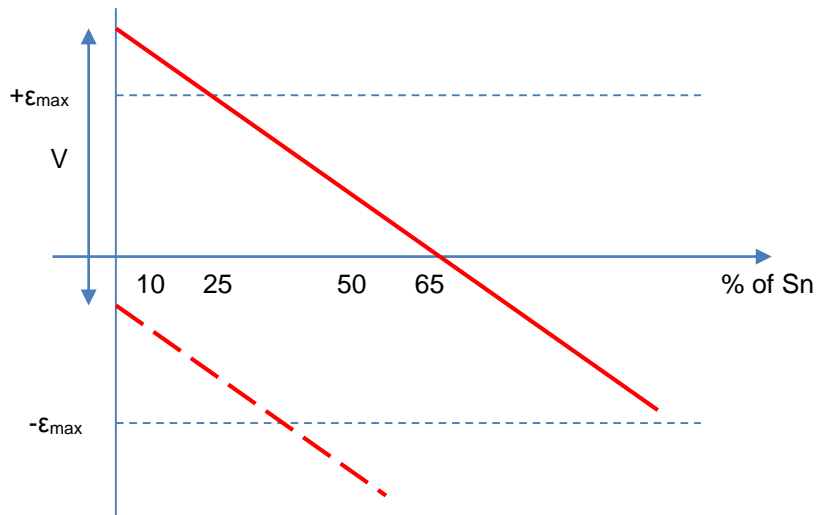

Figure 3. The measuring error as a factor of secondary burden at a constant voltage of the primary

### Voltage Transformers with Multiple Secondary Windings

The voltage transformers can be made with multiple secondary windings. This is accomplished when secondary windings for different applications are required. Each loaded secondary winding will take load current from the primary winding and the overall voltage drop is determined by the sum of the secondary burdens.

The typical design is to provide one Y-connected winding and one additional secondary winding for open delta connection, used for ground fault protection relays. This winding is not loaded during normal operation. Therefore, it will not affect the measuring accuracy. The open delta winding is typically provided with 110 V secondary for solidly grounded systems and for  $110/\sqrt{3}$  V for ungrounded, reactance or resistance grounded systems. This will give an open delta output of 110 V during a solid ground fault in both systems.

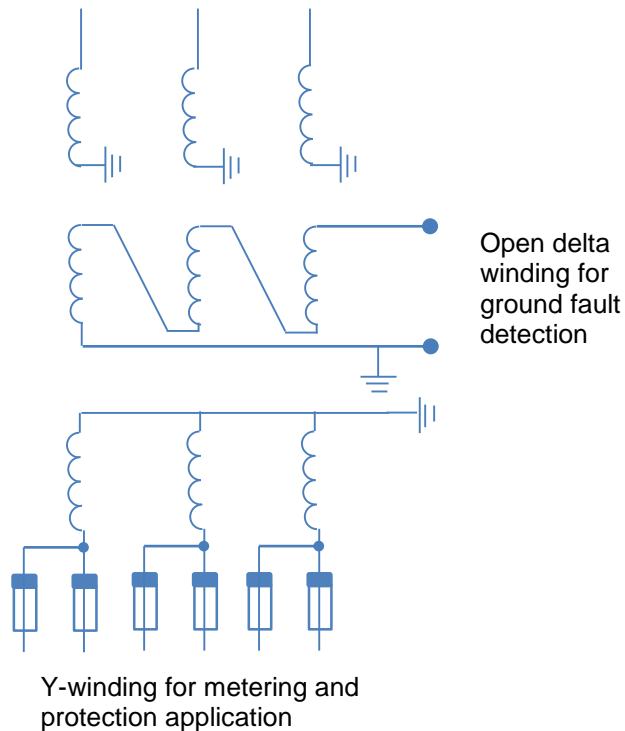

Figure 4. Voltage transformer with two secondary windings, one Y-connected and one Open delta connected

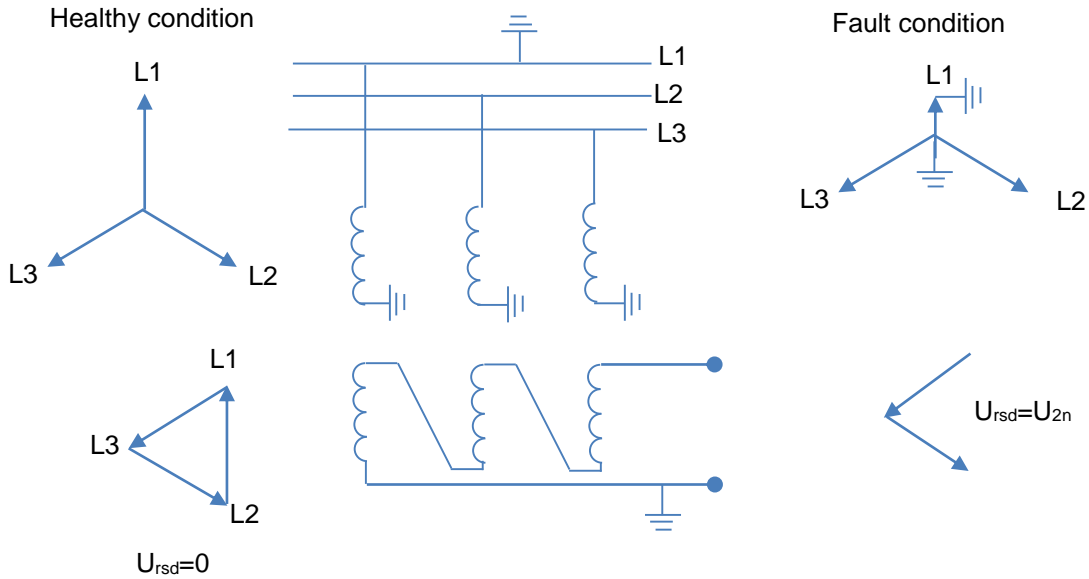

Figure 5. The principle for an open delta winding - Voltages at ground fault in a direct grounded system



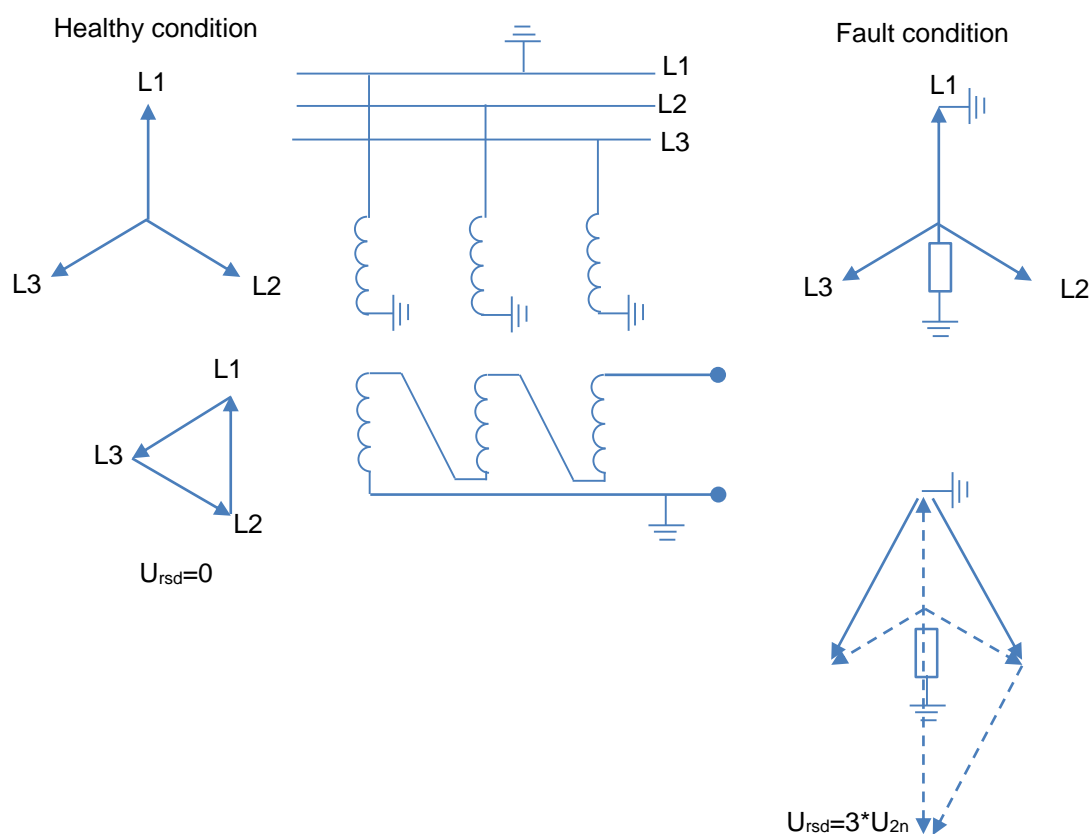

Figure 6. The principle for an open delta winding - Voltages at ground fault in ungrounded or high resistive/resonance grounded system

### Voltage Factor

Typically, voltage transformers are connected between phase and ground. In the case of a fault in the network the voltage across the VT's (CVT's) will be increased in the healthy phases. IEC defines the voltage factors: 1.9 for systems not being solidly grounded and 1.5 for solidly grounded systems.

The saturation is 30 sec for systems with tripping ground fault protection and 8 hours if no ground fault tripping protection is installed. The VT's must not be saturated at the voltage factor.

### Burden and Accuracy Classes

A number of standard rated burden values are presented in IEC 186. Following burdens are preferred: 10, 25, 50, 100, 200 and 500 VA.

The values are rated per phase for a three-phase set. The standard values on burden is presented for  $\cos \phi=0.8$ . The accuracy class is defined for 25-100% of rated burden. Typical burden of modern protection and metering equipment is very low (in range 5-10 VA) and considering that accuracy class is fulfilled down to 25% only a low rated burden should be applied.

A rated burden around “1.5 x connected burden” will provide maximum accuracy at the connected burden. Please refer to Figure 3. Accuracy classes are set for protection purpose and for metering purpose. Table 1 presents IEC 186 requirements for ratio and angle error for different classes.

Table 1. Voltage transformer accuracy classes

Class	Measuring Error $\epsilon$ (%)	Angle error (min)	Purpose
0.2	0.2	10	Metering
0.5	0.5	20	Metering
1	1	40	Instrument
3P	3	120	Protection

It has to be noted that a voltage transformer winding can have a combined class, for example 0.5/3P which means that metering accuracy is accomplished for 80-120% of nominal voltage but the requirement for 5% of nominal voltage and the transient response requirement from protection cores is also accomplished.

### **Class A Equipment Standard Rated Burdens**

The secondary winding rated burden is expressed in watts (W) at rated secondary voltage when rated line-to-ground voltage is impressed across the capacitance voltage divider. The rated burden of the device is the sum of the watt burdens that may be simultaneously impressed on both secondary windings.

Adjustment capacitors are part of the device for connecting in parallel with the burden on one secondary winding to correct the overall-burden power factor to unity or slightly leading. The standard rated burdens of bushing potential equipment are presented in Table 2.

Table 2. Rated burdens of bushing potential equipment

Rated circuit voltage (kV)		Rated Burden (W)
Line to Line	Line to Ground	
115	66.4	25
138	79.7	35
161	93	45
230	133	80
287	166	100

The rated burden of coupling-capacitor potential devices is 150 watts for any of the rated circuit voltages, including those presented in Table 2.

### Class A Equipment Standard Accuracy

Table 3 shows the standard maximum voltage ratio deviation and phase angle for rated burden and for different primary voltage values, with the device adjusted for the specific accuracy at rated primary voltage.

Table 3. Ratio and phase-angle error versus voltage

Primary voltage, % of rated	Maximum Deviation	
	Ratio, %	Phase angle, degrees
100	±1	±1
25	±3	±3
5	±5	±5

Table 4 shows the standard maximum voltage ratio deviation and phase angle for rated voltage and for different burden values with the device adjusted for the specific accuracy at rated burden. Table 4 suggests that for highest accuracy, the burden should not be changed without readjusting the device.

Table 4. Ratio and phase-angle error versus burden

Burden, % of rated	Maximum Deviation	
	Ratio, %	Phase angle, degrees
100	±1	±1
50	±6	±4
0	±12	±8

## Non-Linear Burdens

A "non-linear" burden is a burden whose impedance decreases due to magnetic saturation when the impressed voltage is increased. Big non-linearity in its burden will put capacitance potential equipment into ferroresonance during which steady over-voltages of highly distorted waveform will exist across the burden. Since these voltages bear no resemblance to the primary voltages, such situation has to be avoided. If the maximum tolerable degree of non-linearity has to be known, manufacturer needs to be consulted. Alternatively, the ferroresonance situation can be avoided if all magnetic circuits constituting the burden function at rated voltage at such low flux density that any possible momentary overvoltage will not make the flux density of any magnetic circuit to exceed the knee of its magnetization curve (or will not make the flux density to surpass about 100,000 lines per square inch). Since the secondary-winding voltage of the potential-device may increase to  $\sqrt{3}$  times rated, and the broken-delta voltage may increase to  $\sqrt{3}$  times rated, the corresponding line-to-neutral and broken-delta burdens may be required to have no more than  $1/\sqrt{3}$  and  $1/3$ , respectively, of the maximum allowable flux density at rated voltage. If burdens with closed magnetic circuits, such as auxiliary potential transformers, are not installed, there is no chance of ferroresonance. Class A potential equipment is equipped with two secondary-windings to avoid the requirement for an auxiliary potential transformer. Typically used protection relays, meters, and instruments have air gaps in their magnetic circuits, or function at low flux density to make their burdens sufficiently linear.

## The Broken-Delta Burden and the Winding Burden

The broken-delta burden is typically composed of the voltage-polarizing coils of ground directional protection relays. Each protection relay's voltage-coil circuit has a series capacitor to ensure relay has a lagging angle of maximum torque. Consequently, the voltage-coil circuit has a leading power factor. The burden of each protection relay is determined by the manufacturer in terms of the rated voltage of the protection relay. The broken-delta burden has to be expressed in terms of the rated voltage of the potential-device winding or the tapped portion of the winding whichever is used for making up the broken-delta arrangement. If the protection relay - and winding-voltage ratings are the same, the broken-delta burden is the sum

of the protection relay burdens. If the voltage ratings are different, protection relay burdens must be re-expressed in terms of the voltage rating of the broken-delta winding before adding them, remembering that the volt-ampere burden will change as the square of the voltage, in the case there is no saturation.

The actual volt-ampere burdens imposed on the individual windings comprising the broken-delta arrangement are highly variable and are only indirectly related to the broken delta burden. Typically, the three winding voltages sum vectorially to zero. Hence, no current goes into the circuit, and the burden on any of the windings is zero. When ground faults happen, the voltage that appears across the broken-delta burden corresponds to 3 times the zero-phase-sequence component of any one of the three phase-to-ground voltages at the potential-device location. This voltage is known as " $3V_0$ ". The real amplitude of this voltage is depends on how solidly the system neutrals are grounded, on the location of the fault with respect to the potential device, and on the transmission circuit arrangement since it affects the amplitude of the zero phase-sequence reactance. For faults at the potential-device location, for which the voltage is the biggest,  $3V_0$  can vary roughly from 1 to 3 times the rated voltage of each of the broken-delta windings. (This voltage can get even bigger in an ungrounded-neutral system in the case of ferroresonance). If we assume no magnetic saturation in the burden, its maximum current amplitude will change with the voltage over a 1 to 3 range. The burden current flows through the three broken-delta windings in series. As presented in Figure 7, the current is at a different phase angle with respect to each of the winding voltages. Since a ground fault can happen on any phase, the positions of any of the voltages of Figure 7 relative to the burden current can be interchanged. Therefore, the burden on each winding may have a wide range of characteristics under different conditions. Another peculiarity of the broken-delta burden is that the load is carried by the windings of the unaffected phases, and that the voltages of these windings do not change in direct proportion to the voltage across the broken-delta burden. The voltages of the unaffected-phase windings are not nearly as variable as the broken-delta-burden voltage.

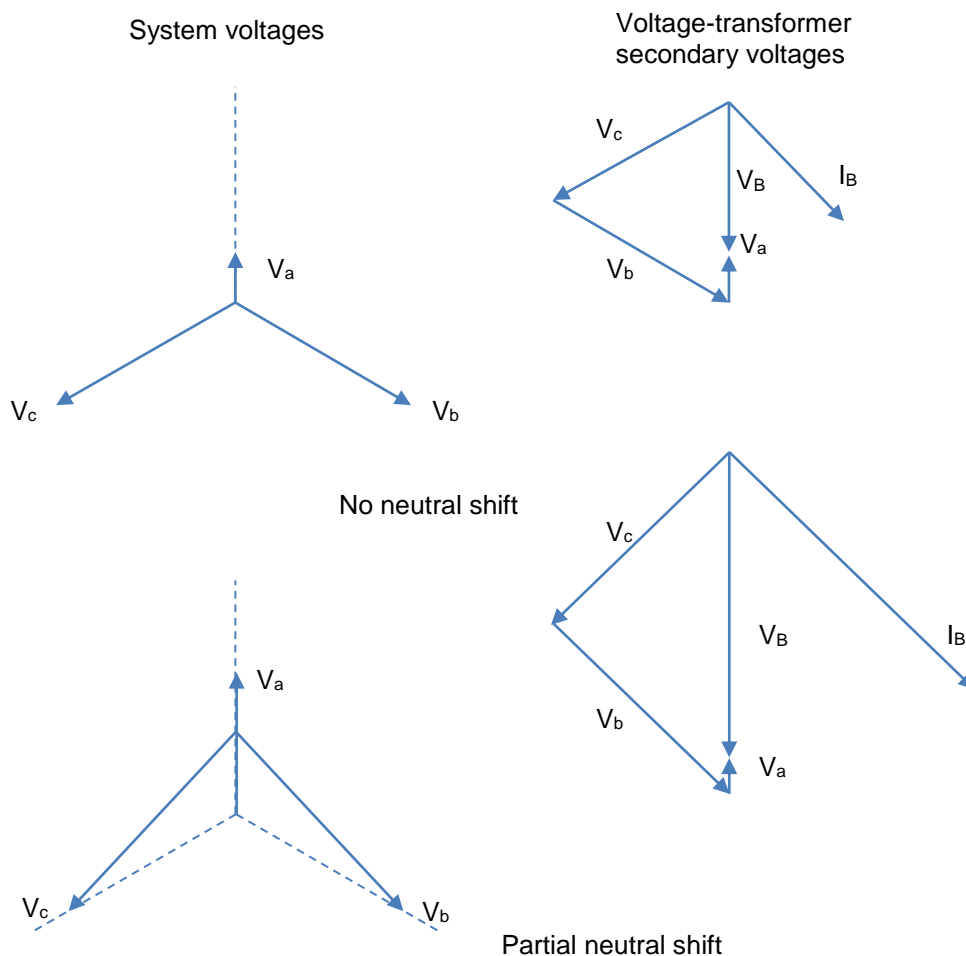

Figure. 7. Broken-delta voltages and current for a single-phase-to-ground fault on phase

The winding voltages of the unaffected phases change from rated voltage to  $\sqrt{3}$  times rated voltage. The broken-delta-burden voltage, and therefore the current, is changing from less than rated to 3 times rated. As a consequence, on the basis of rated voltage, the burden on any winding can change from less than the broken-delta burden to  $\sqrt{3}$  times it. For estimating exercises the,  $\sqrt{3}$  multiplier would be used, but, if the overall burden appeared to be excessive, the actual burden would have to be determined. To do this, the following steps are taken:

1. Determine  $3V_0$  for a single-phase-to-ground fault at the potential-device location, and present this in secondary-voltage terms, using as a potential-device ratio the ratio of normal phase-to-ground voltage to the rated voltage of the broken-delta windings.

2. Divide  $3V_0$  by the impedance of the broken-delta burden to find the current magnitude that will circulate in each of the broken-delta windings.
3. Determine the phase-to-ground voltage ( $V_{b1} + V_{b2} + V_{b0}$  etc.) of each of the two unaffected phases at the voltage-transformer location, and present it in secondary-voltage terms as for  $3V_0$ .
4. Multiply the current of (2) by each voltage of (3).
5. Present the volt-amperes of (4) in terms of the rated voltage of the broken-delta windings by multiplying the volt-amperes of (4) by the ratio:

$$\left[ \frac{V_{rated}}{\text{Voltage of } 3} \right]^2 \quad (13)$$

It is common to treat the volt-ampere burden as though it were a watt burden on each of the three windings. It will be evident from Figure 7 that, depending on which phase is grounded that the volt-ampere burden on any winding could be practically all watts.

It is not common practice to correct the power factor of the broken-delta burden to unity as is done for the phase burden. Because this burden typically has a leading power factor, power factor correction to unity would demand an adjustable auxiliary burden that had inductive reactance. Such a burden would have to have very low resistance and it would have to be linear. In the face of these severe demands, and in view of the fact that the broken-delta burden is typically a small part of the overall potential-device burden, such corrective burden is not provided in standard potential equipment.

### **Coupling Capacitor Insulation Coordination**

The coupling capacitor voltage rating is used with protective relaying. Its insulation needs to withstand the flashover voltage of the circuit at the point where the capacitor is connected. Table 5 presents the typical capacitor withstand test voltages for some circuit-voltage ratings for altitudes below 3300 feet. The circuit flashover voltage at the capacitor location depends not only on the line insulation but also on

the insulation of other equipment such as circuit breakers, transformers, and lightning arresters. Nevertheless, there may be situations when these other terminal devices may be disconnected from the line, and the capacitor will then be left alone at the end of the line without benefit of the protection that any other equipment might provide. For instance, a switch may be opened between a breaker and the capacitor, or a breaker may be opened between a transformer or an arrester and the capacitor. In those situations, the capacitor must be able to withstand the voltage that will dash over the line at the point where the capacitor is connected.

Table 5. Typical withstand test voltages for coupling capacitors

Rated circuit voltage, kV		Withstand test voltages		
Phase to phase	Phase to Ground	Impulse, kV	Low frequency	
			Dry 1-Min (kV)	Wet 10-Sec (kV)
115	66.4	550	265	230
138	79.7	650	320	275
161	93	750	370	315
230	133.0	1050	525	445
287	166.0	1300	655	555

Some transmission lines are over-insulated, either because they are subjected to unusual insulator contamination or because they are insulated for a future bigger voltage than the present operating value. In any case, the capacitor needs to withstand the actual line flashover voltage unless there are other devices permanently connected to the line that will hold the voltage down to smaller value.

At altitudes above 3300 feet, the flashover value of air-insulated devices decreases. To compensate for this decrease, extra insulation may be needed for the line and for the other terminal devices. This may demand the next higher standard voltage rating for the coupling capacitor, and it is the common to specify the next bigger rating if the altitude is known to be over 3300 feet.

In the case a coupling capacitor potential device is meant to operate at the next standard rated circuit voltage below the coupling capacitor rating, the manufacturer has to be informed. In such situation, a special auxiliary capacitor will be provided that will give normal tap voltage although the applied voltage is one step less than rated.



This will give the device a rated burden of 120 watts. If a special auxiliary capacitor were not provided, the rated burden would be roughly 64% of 150 watts instead of 80%. This also applies for bushing potential devices, except that sometimes a nonstandard transformer unit may be needed to get 80% of rated output when the device is working at the next standard rated circuit voltage below the bushing rating.

### **Voltage Transformer Output**

The output needed from a voltage transformer core depends on the application and the type of the connected load.

Equipment like kWh or kArh meters work under normal load conditions. For metering cores a high precision for voltages in range (80-120 %) of nominal voltage is needed. Accuracy classes for metering cores are (0.1 laboratory), 0.2, 0.5 and 1.0.

In the case of protection relays and disturbance recorders data about a primary disturbance must be transferred to the secondary side. For such windings a lower precision is needed but a high capability to transform voltages from “ $5-V_f \times$  rated voltage” is required since protection relays must measure and disconnect the fault. Also, a good transient response is needed for the protection transformers and this is a problem for CVT's where the energy stored in the capacitive voltage divider and in the interposing voltage transformer (IVT) will result in a transient voltage oscillation on the secondary side.

The transient oscillation has a low frequency component (2-15 Hz) and a high frequency oscillation component (900-4000 Hz), as shown in Figure 7. The time constant for the high frequency component is short (<10ms) whereas the low frequency component has long time constants. The magnitude is determined by the fault inception angle. Bigger capacitances in the voltage divider give lower amplitude of the low frequency oscillation. The IEC 186 indicates that the secondary value, one cycle after a solid short circuit shall be lower than 10%.

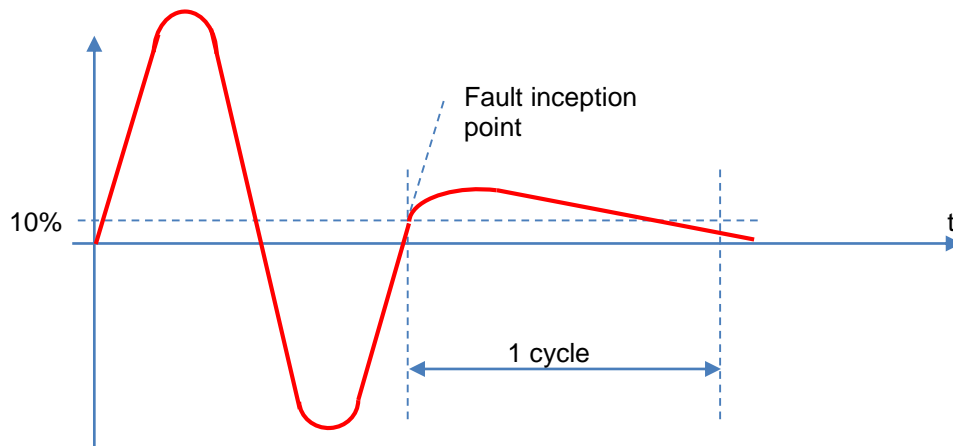

Figure 7. The transient voltage at a solid short circuit on the CVT terminals

### Ferro Resonance

Ferro resonance can happen in circuits that have a capacitor and a reactor with an iron core (a non-linear inductance). Both the CVT and a magnetic VT can experience Ferro-resonance phenomenon.

The Ferro-resonance for a magnetic VT is an oscillation between the VT inductance and the network capacitance. Ferro resonance can happen at ungrounded networks. However, some parts of the network can become ungrounded under certain conditions. Typically, an oscillation is triggered by a sudden change in the network voltage. Ferro resonance situation can happen with sub-harmonic frequencies and with harmonic frequencies. Typically, it is difficult to understand when a risk of Ferro-resonance increases but as soon system with a voltage transformer is left ungrounded, preventive actions should be considered (the risk of capacitive charged systems with a VT needs also to be considered).

The Ferro-resonance damping is typically done with a 27-60  $\Omega$ , 200 W resistor connected across the open delta winding. The resistor value should provide a current as high as possible but a current which is below the thermal rating of the voltage transformer.

The CVT with its capacitor and Instrument Voltage Transformer (IVT) is by itself a Ferro-resonance circuit. The process is triggered by a sudden voltage change. A sub-harmonic oscillation can be triggered and must be damped to stop transformer

damage. The IEC standard defines that CVT's must be equipped with Ferro-resonance damping elements. Typically, this consists of a saturating reactor and a resistor in each phase.

### Secondary Circuit Fusing

Secondary fuses need to be installed at the first box where the three phases are brought together. The circuit before the first box from the terminal box is made to minimize fault risks in the circuit. Fuses in the three phase box are provided to enable a fusing of the circuits for different loads like protection and metering. The fuses must be chosen to provide fast and reliable fault clearance. This needs to be done for a fault at the end of the cabling. Ground faults and two-phase faults need also to be examined.

### Secondary Cabling Voltage Drop

The voltage transformer accuracy is expressed on the secondary terminal. The secondary cabling voltage drop and angle error need to be examined in order to confirm the overall circuit accuracy. The secondary cabling voltage drop and angle error need to be lower than the error given by the transformer class specification. The voltage drop for a voltage transformer secondary circuit is shown in Figure 8.

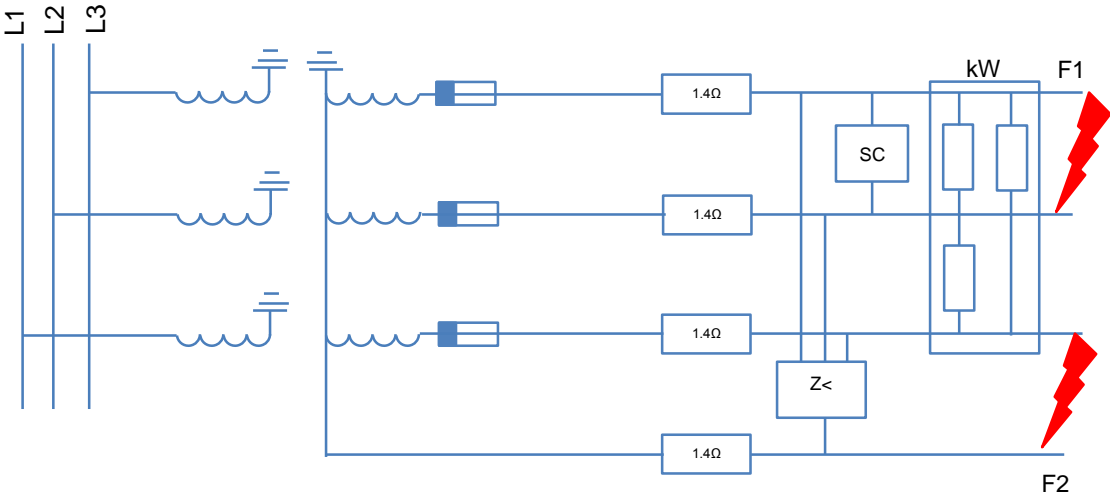

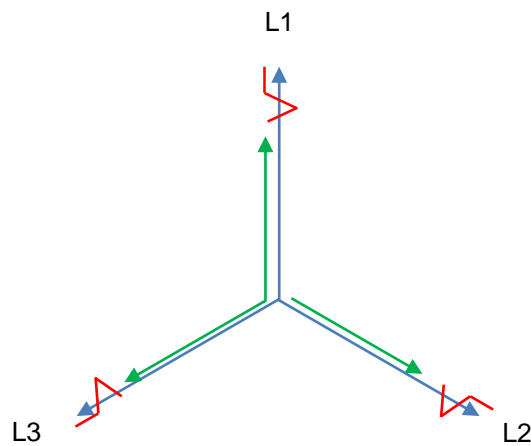

Figure 8. The voltage transformer secondary circuit voltage drop

### Overloading Effect

Once the burden surpasses the rated value, the errors will increase at about the rate shown by extrapolating the data shown in Table 4. Apart from the chance of overheating, the serious effect is the associated increase of the tap voltage. As the burden is increased above the rated value, the tap voltage will increase roughly proportionally. The objection to increasing the tap voltage is that the protective gap has to be adjusted for higher-than-normal arc-over voltage. The circuit elements protected by the gap are selected to withstand 4 times the normal tap voltage for 1 minute. The gap is adjusted to arc over voltage at about twice normal voltage. This is about as low an arc-over as the gap may be adjusted to have in view of the fact that for some ground faults the applied voltage may increase to  $\sqrt{3}$  times normal. Apparently, the gap must not be allowed to arc over for any voltage for which the protective-relaying equipment must function. Since the ground-relay burden loads the devices only when a ground fault happens, gap flashover may be a problem when thermal overloading is not a problem. Before purposely overloading a capacitance potential device, manufacturer needs to be consulted. As might be suspected, short-circuiting the device secondary terminals (which is extreme overloading) will arc over the gap continuously for the duration of the short circuit. This may not create any damage to the device, and therefore it may not require fusing, but the gap will get damaged to such an extent that it may no longer protect the equipment. Even in situations when it is properly adjusted, the protective gap might arc over during transient over-voltages that are created by switching or by

lightning. The duration of such arc-over is so short that it will not interfere with the proper service of protective relays. The moment the overvoltage ceases, the gap will stop arcing over.

It is important to mention that the standard rated burdens are specified as though a device were connected and loaded as a single-phase element. Nevertheless, in reality the secondary windings of three devices are interconnected and jointly loaded. Hence, to find the real loading on a particular element under unbalanced voltage conditions, as when short circuits happen, certain conversions must be done. The effective burden on each device resulting from the line-to-line and line-to-neutral burdens need to be checked in the case the loading is critical. This is a circuit problem that is applicable to any voltage transformer type.

### **Instrument Voltage Transformers (IVT) and Capacitance Voltage Transformer (CVT) Comparison**

Capacitance voltage devices are used for protective relaying only when they are considerably less expensive than voltage transformers. Voltage devices are not as precise as voltage transformers, and also they may have unwanted transient inaccuracies unless they are properly loaded. When a voltage source for the protective relays of a single circuit is needed, and when the circuit voltage is roughly 69 kV and higher, coupling-capacitor voltage devices are less expensive than voltage transformers. Financial savings may be realized below 69 kV if carrier current is involved, because a voltage device coupling capacitor can be also used, with small extra expense, for coupling the carrier-current equipment to the circuit. Bushing voltage devices, being still less expensive, may be even more economical, provided that the devices have sufficiently high rated burden capacity. Nevertheless, the main capacitor of a bushing voltage device cannot be used to couple carrier-current equipment to a power circuit. Once compared on a dollars per-volt-ampere basis, voltage transformers are much cheaper than capacitance voltage devices.

When two or more transmission-line sections are connected to a common bus, a single set of voltage transformers connected to the bus will typically have adequate capacity to supply the protective-relaying equipment of all the transmission lines, whereas one set of capacitance voltage devices may not. The provision of extra

voltage devices will quickly nullify the cost difference. In view of the above mentioned, bus voltage transformers should be at least considered, even for a single circuit, in the case there is a likelihood that future requirements might involve more circuits.

Voltage transformers energized from a bus give additional advantage where protective-relaying equipment is involved in which dependence is placed on "memory action" for reliable service. When a transmission line section protected by such relaying equipment is closed in on a nearby short circuit, and if voltage transformers connected to the bus are involved, the protection relays will have voltage on them before the line breaker was closed, and therefore the memory action can be efficient. In the case the voltage source is on the line side of the breaker, which is typically true with capacitance voltage devices, there will be no voltage on the relays initially, and memory action will be ineffective. Therefore, the protection relays may not work if the voltage is too low owing to the presence of a metallic fault with no arcing. Therefore it requires back-up protection relaying at other locations to clear the fault from the system.

Some people object to bus voltage transformers on the basis that trouble in a voltage transformer will affect the protective relaying of all the lines connected to the bus. This is not too severe objection, especially if the line relays are not allowed to trip on loss of voltage during normal load, and if a voltage-failure alarm is installed.

In the case of the ring buses, there is no satisfactory location for a single set of bus voltage transformers to serve the protection relays of all circuits. In such situations, capacitance voltage devices on the line side of the breakers of each circuit are the best solution in the case they are less expensive.

In the case there are step-down power transformers at a location, where voltage is needed for protective-relaying equipment, the question naturally arises whether the protection relay voltage can be obtained from the low-voltage side of the power transformers, and thereby avoid the expense of a high-voltage source. Such a low-voltage source can be used in specific situations.

The first condition is the source reliability. In the case, there is only one power transformer, the source will be lost if this power transformer is removed from service for any reason. In the case there are two or more power transformers in parallel, the source is probably sufficiently reliable if the power transformers are equipped with separate breakers.

The second condition is whether there will be a suitable source for polarizing directional-ground protection relays if such protection relays are needed. If the power transformers are wye delta connected, with the high-voltage side connected in wye and the neutral grounded, the neutral current can be used for polarizing. Certainly, the question of whether a single power transformer can be relied on needs to be considered. In the case high-voltage side is not a grounded wye, then a high-voltage source has to be provided for directional-ground relays, and it may as well be used also by the phase protection relays. Finally, if distance relays are installed, the desirability of "transformer-drop compensation" must be examined. Directional-overcurrent protection relays can use any conventional voltage-transformer connection.

The voltage transformer terminals are marked to show the relative polarities of the primary and secondary windings. Typically, the corresponding high-voltage and low voltage terminals are labelled "H<sub>1</sub>" and "X<sub>1</sub>", respectively (and "Y<sub>1</sub>" for a tertiary). In capacitance voltage devices, only the X<sub>1</sub> and Y<sub>1</sub> terminals are labelled, the H<sub>1</sub> terminal being obvious from the equipment configuration.

The polarity marks have the same importance as for current transformers, namely, that, when current enters the H<sub>1</sub> terminal, it leaves the X<sub>1</sub> (or Y<sub>1</sub>) terminal. The relation between the high and low voltages is such that X<sub>1</sub> (or Y<sub>1</sub>) has the same instantaneous polarity as H<sub>1</sub>, as presented in Figure 9.

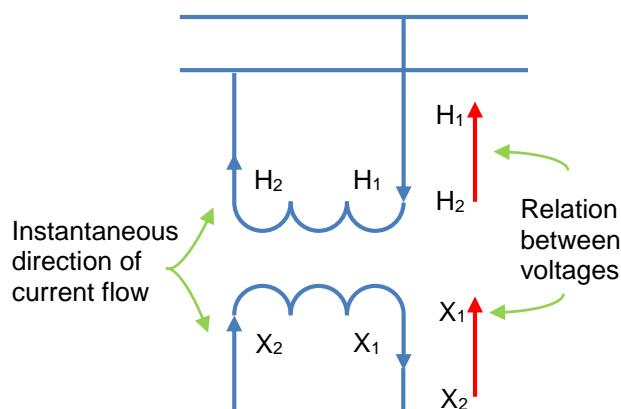

Figure 9. Importance of voltage transformer polarity marks

Distance relays for interphase short circuits must be equipped with voltage corresponding to primary line-to-line voltage. Any of the three connections presented in Figure 10 may be used. Connection A is selected when polarizing voltage is needed also for directional ground relays. Connections B and C do not provide means for polarizing directional-ground relays. Connection C is typically used because it is less expensive since it uses only two potential transformers. The burden on each voltage transformer is less in connection B, which is the only reason it would ever be selected.

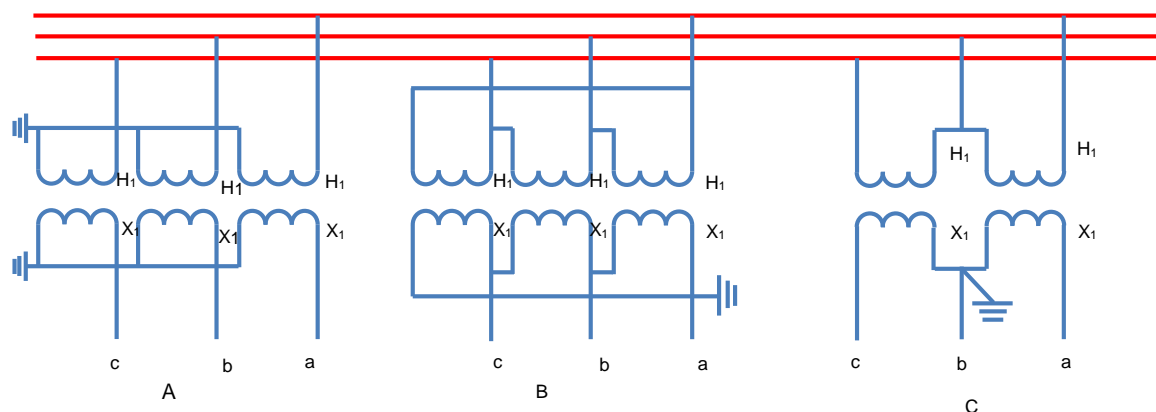

Figure 10. Voltage transformer connections for distance relays

The voltages between the secondary leads for all three configurations shown in Figure 10 are the same, and in terms of symmetrical components can be expressed as:

$$V_{ab} = V_a - V_b$$



$$\begin{aligned}
&= V_{a1} + V_{a2} + V_{a0} - V_{b1} - V_{b2} - V_{b0} \\
&= (1 - a^2)V_{a1} + (1 - a)V_{a2} \\
&= \left(\frac{3}{2} + j\frac{\sqrt{3}}{2}\right)V_{a1} + \left(\frac{3}{2} - j\frac{\sqrt{3}}{2}\right)V_{a2} \tag{14}
\end{aligned}$$

Similarly,

$$\begin{aligned}
V_{bc} &= (1 - a^2)V_{b1} + (1 - a)V_{b2} \\
&= a^2(1 - a^2)V_{a1} + a(1 - a)V_{a2} \\
&= (a^2 - a^2)V_{a1} + (a - a^2)V_{a2} \\
&= -j\sqrt{3}V_{a1} + j\sqrt{3}V_{a2} \tag{15}
\end{aligned}$$

$$\begin{aligned}
V_{ac} &= (1 - a^2)V_{c1} + (1 - a)V_{c2} \\
&= a(1 - a^2)V_{a1} + a^2(1 - a)V_{a2} \\
&= (a - 1)V_{a1} + (a^2 - 1)V_{a2} \\
&= \left(-\frac{3}{2} + j\frac{\sqrt{3}}{2}\right)V_{a1} + \left(-\frac{3}{2} - j\frac{\sqrt{3}}{2}\right)V_{a2} \tag{16}
\end{aligned}$$

### Low-Tension Voltage for Distance Relays

The voltage transformers must be connected to the low-voltage source in such a way that the line-to-line voltages on the high-voltage side are reproduced. The connection that needs to be used will depend on the power-transformer connections. If the power-transformer bank is connected wye-wye or delta-delta, the voltage transformer connections would be the same as though the voltage transformers were on the high-voltage side. Nevertheless, the power transformers are typically connected wye-delta or delta-wye.

First, let us become familiar with the standard method of connecting wye-delta or delta-wye power transformers. Incidentally, in stating the connections of a power-transformer bank, the high-voltage connection is stated first; therefore a wye-delta transformer bank has its high-voltage side connected in wye, etc. The standard method for power transformer connections is not applicable to voltage transformers

(which are connected as needed), but the technique used for making the desired connections is also applicable to voltage transformers.

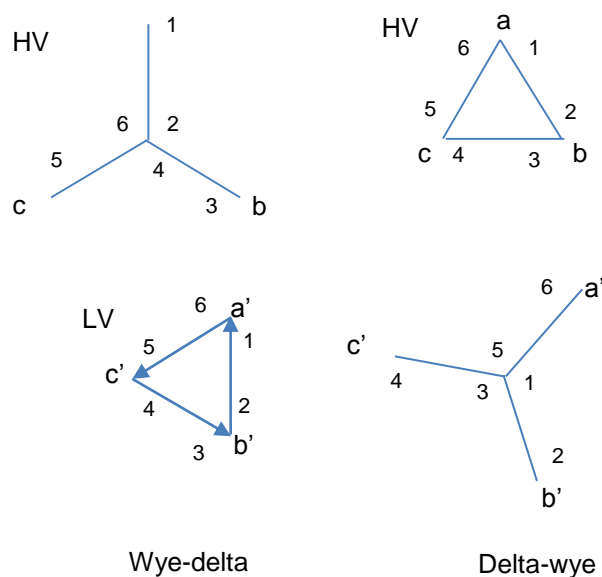

Figure 11. Three-phase voltages for typical power transformer connections

The standard power transformer connection is that, with balanced three-phase load on the transformer bank, the current in each phase on the high-voltage side will lead by  $30^\circ$  the current in each corresponding phase on the low-voltage side. Also, the no-load line-to-line voltages on the high voltage side will lead the corresponding low-voltage line-to-line voltages by  $30^\circ$ . For this to be true, the line-line voltages have to be as in Figure 11, where a' corresponds to a, b' to b, and c' to c. The numbers on the voltage vectors shown in Figure 11 designate the corresponding ends of the transformer windings, 1-2 designating the primary and secondary windings of one transformer, etc. Let us consider three single-phase transformers shown in Figure 12 with their primary and secondary windings designated 1-2, etc. If we assume that the transformers are rated for either line-to-line or line-to ground connection, it is only necessary to connect together the numbered ends that are presented connected in Figure 11, and the connections shown in Figure. 13 will result.

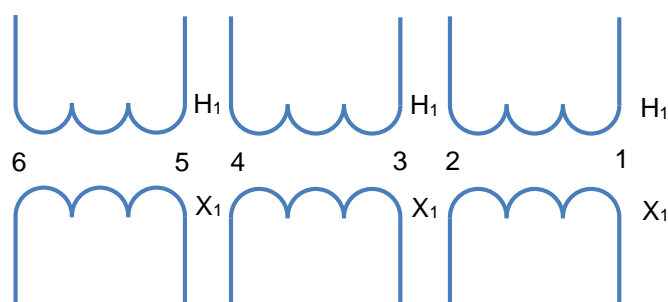

Figure 12. Numbering transformer end windings preparatory to making three-phase connections

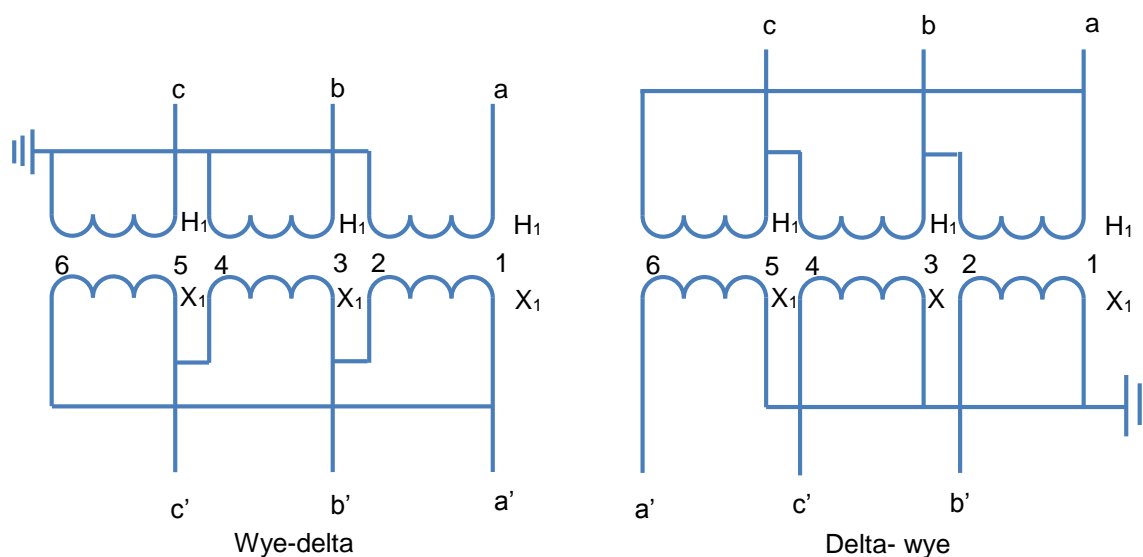

Figure 13. Interconnecting the transformers of Figure 12 according to Figure 11 to obtain typical connections

We can now move on to examine the voltage transformer connections on the low voltage side that are used for the purpose of supplying voltage to distance protection relays. Figure 14 presents the connections if the power transformers are wye-delta connected. Figure 15 shows the connections if the power transformers are delta-wye connected.

For either power-transformer connection, the line-to-line voltages on the secondary side of the voltage transformers will contain the same phase-sequence components as those derived for the connections of Figure 10, if we neglect the voltage drop or rise due to load or fault currents that may flow through the power transformer.

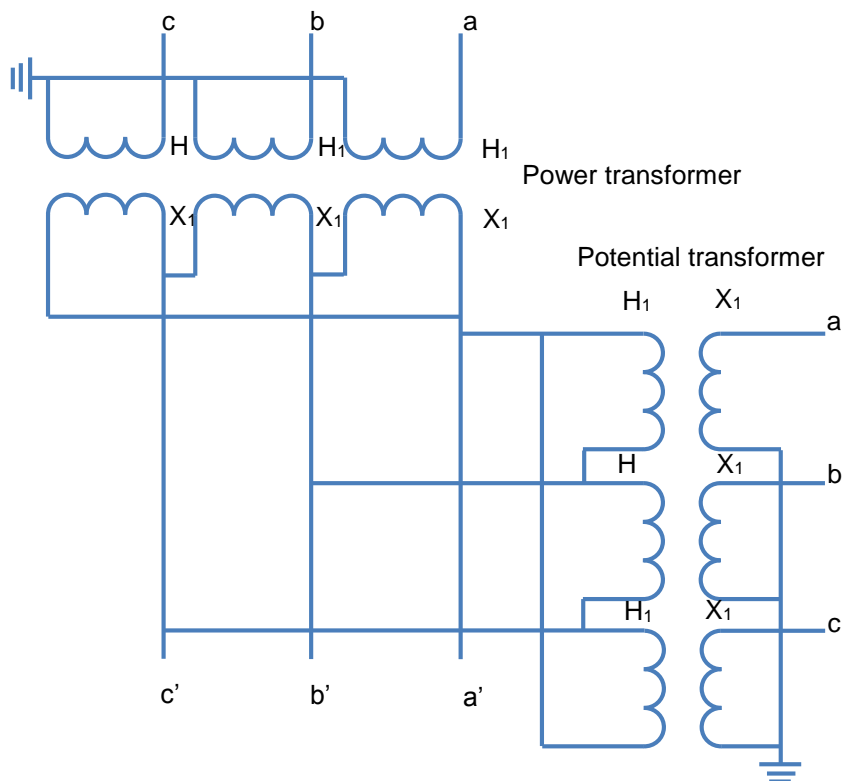

Figure 14. Voltage transformer connections on low-voltage side of wye-delta power transformer for use with distance protection relays

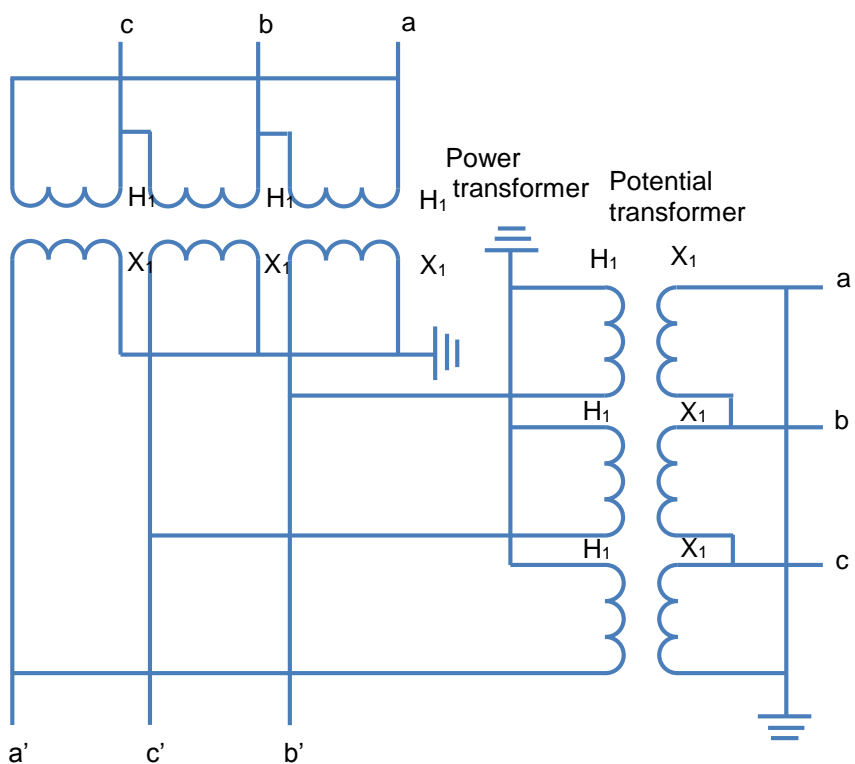

Figure 15. Voltage transformer connections on low-voltage side of delta-wye power transformer for use with distance protection relays

If, for one reason or another, the voltage transformers must be delta-delta or wye-wye connected, or if the voltage magnitude is incorrect, auxiliary voltage transformers must be installed to obtain the needed voltages for the distance protection relays.

The information given for making the needed connections for distance protection relays should be sufficient instruction for making any other desired connections for phase relays.

### Connections for Obtaining Polarizing Voltage for Directional-Ground Relays

The connections for obtaining the needed polarizing voltage are presented in Figure 16. This is known the "broken-delta" connection. The voltage that appears across the terminals can be written as:

$$\begin{aligned}
 V_{nm} &= V_a + V_b + V_c \\
 &= (V_{a1} + V_{a2} + V_{a0}) + (V_{b1} + V_{b2} + V_{b0}) + (V_{c1} + V_{c2} + V_{c0}) \\
 &= V_{a0} + V_{b0} + V_{c0} = 3V_{a0} = 3V_{b0} = 3V_{c0} \qquad (17)
 \end{aligned}$$

In other words, the polarizing voltage is 3 times the zero-phase-sequence component of the voltage of any phase.

The actual connections in a specific situation will depend on the voltage transformer type that is involved and on the secondary voltage needed for other than ground relays. In the case voltage for distance relays needs to be provided, the connections presented in Figure 17 should be used. If voltage is needed only for polarizing directional-ground relays, three coupling capacitors and one voltage device, connected as shown in Figure 18 would suffice. The voltage obtained from this connection is 3 times the zero-phase-sequence component.

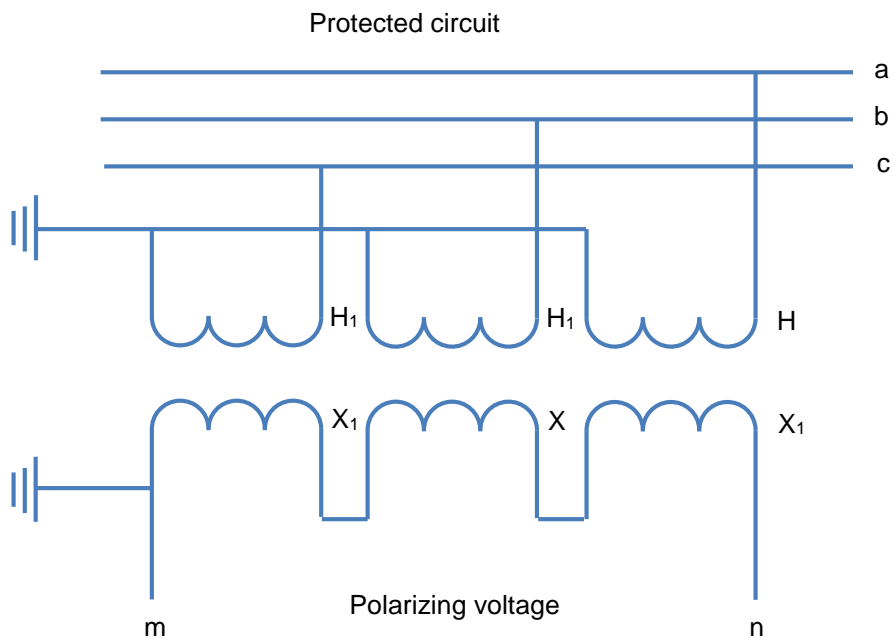

Figure 16. The broken-delta connection

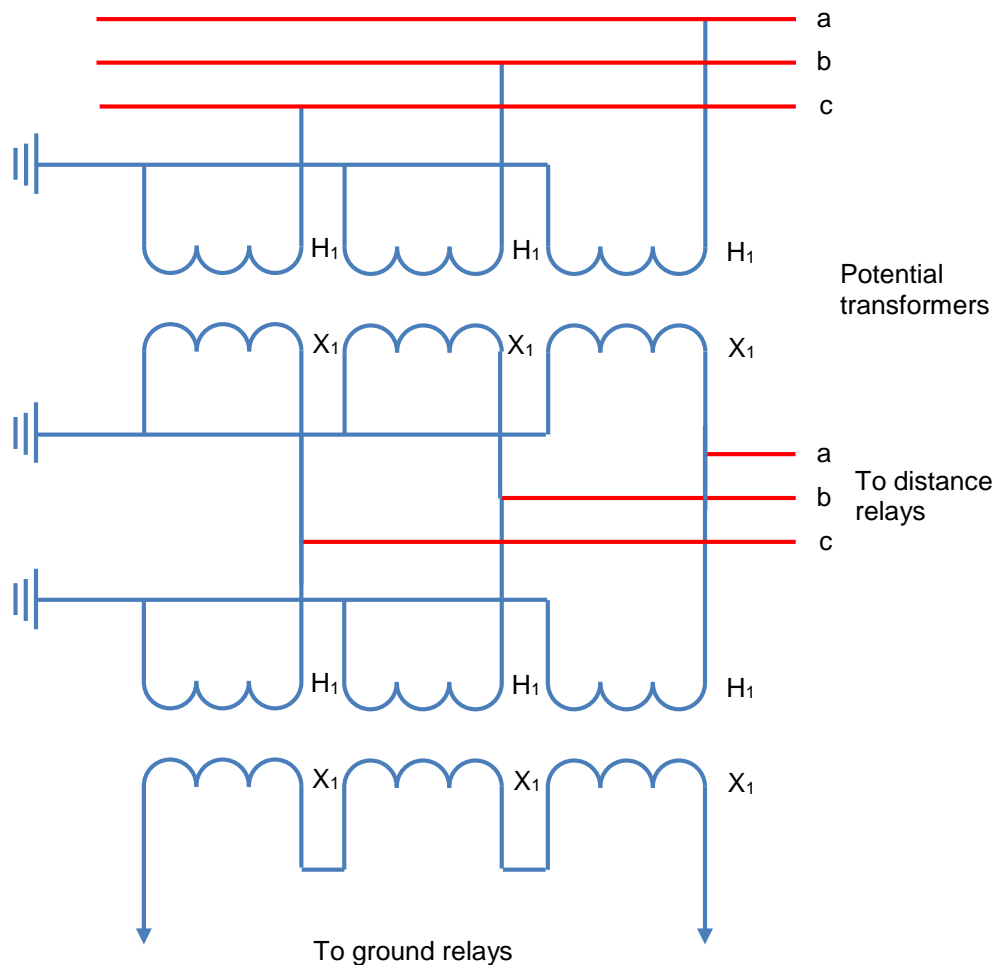

Figure 17. Voltage transformer connections for distance and ground relays

The connection presented in Figure 18 cannot always be duplicated with bushing voltage devices because at least some of the capacitance corresponding to the auxiliary capacitor might be an integral part of the bushing and could not be separated from it. The capacitance to ground of interconnecting cable may also have a significant impact.

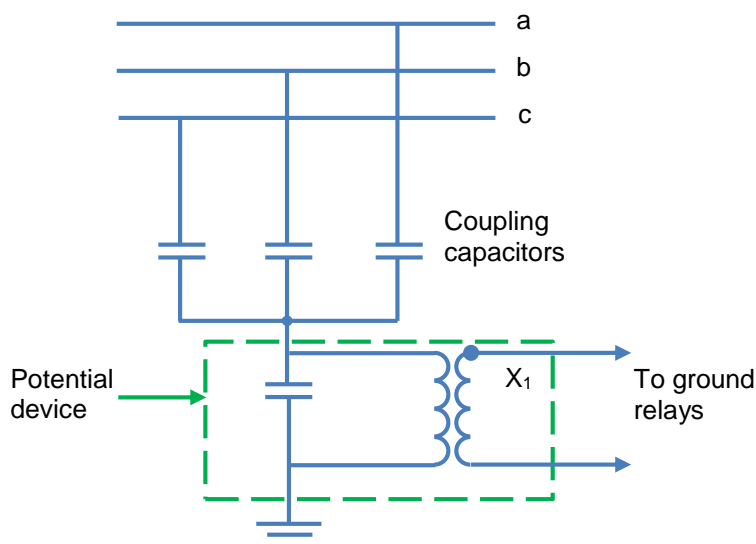

Figure 18. Connection of three coupling capacitors and one voltage device for providing polarizing voltage for directional-ground protection relays

The three capacitance tape may be connected together, and a special voltage device may be connected across the tap voltage as presented in Figure 19, but the rated burden may be less than those shown in the Table 2.

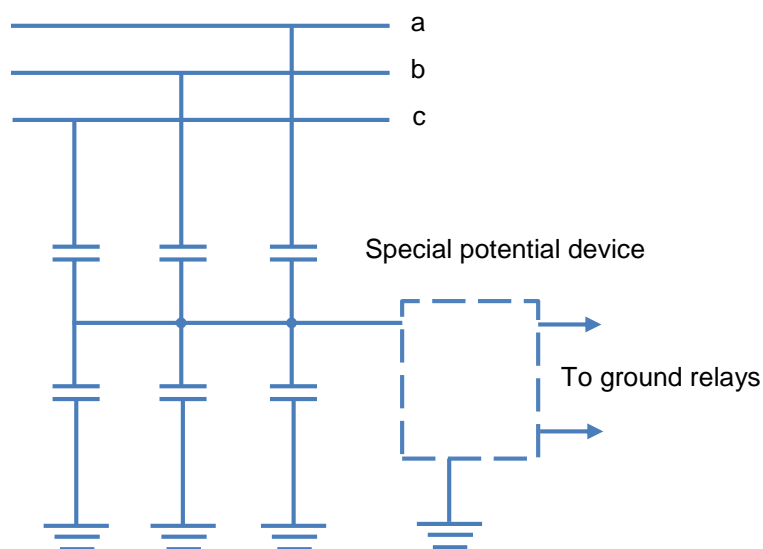

Figure 19. Use of one voltage device with three capacitance bushings